

# 1 Course Blind Nail

Standard Nailing Instructions  
For 7-1/8", 6.0" & 5.3" *Bevel top* panels

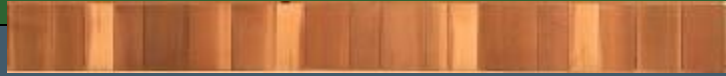

*In the event Cedar Valley published application instructions conflict or contradict local building codes, please call the factory for clarification. If no local codes exist, refer to the I.C.C. residential building codes and these instructions for guidelines.*

## FIRST DETERMINE CORNER TYPE:

With Flush-mounting corners or corner board, install corner first. Double wrap building corners with moisture barrier. Attach corners using one corrosion resistant ring shank siding nail per corner side, 1.4" down from top edge, centered on each side. Apply the 4 marked corner units provided in order A,B,C,D (repeating). Start with any piece but retain the order or the "Boston Weave" will be off. Caulk corner plywood edges well. Trim panel end and push against caulked corner edge. Set corners with each row of panels, do not install all corners first. Nail panel as per instructions below. (See Page 2 for further information.)

## PANEL APPLICATION:

Plan panel layout from lowest building corner after determining corner style to be used. Hold panels 6" off grade and 1" off roofs or decks but tight to window & door trim. Panels must be applied over nailable shear sheathing fastened onto studs, 16" O.C. A ring shank corrosion resistant siding nail with length of 6D to 8D is required for codes. A code approved building paper, must be applied directly behind the panels. Panels must span at least one stud spacing and vertical end joints must be staggered so they do not land on the same stud. Around windows, doors or other penetrations cut the panel to fit tightly and caulk the joint between panel & trim. Installers should use Best Construction Practices for issues not addressed here.

*NOTE: Panels do not meet shear requirements!*

## NAILING INSTRUCTIONS:

**For Evenbutt panels** (Figure 1) nail 16" O.C. There are dual lines scribed across the top of each panel. The bottom line is the lay line for panel placement. The upper line is for *nail* placement. *Make sure to drive all nails near the upper line!* This ensures max wind uplift resistance & conceals the fastener with the next row of panels. (Figure 2) Additional instructions below.

**For Staggered buttline panels** measure & nail 1.4-inch down from top of panel every 16-inch O.C. Additional instructions below.

**For All Panels:** Nail all panels STARTING ½ inch in from one edge and working across the panel. Never nail from both edges towards the middle. Each nail must hit the 2X4 stud or 7/16" nailable shear sheathing. Nail head should be flush with the surface of the panel. **DO NOT OVERDRIVE!** If nailing to ½" plywood, panel ends do not have to join on studs however the nails holding panels should be driven into studs. If needed, additional stainless nails can be driven 1.5" from the bottom to help pull the panel tightly to the wall. **Maximum stud distance is 16 inches O.C. for these nailing patterns!**

**In high wind areas above 80 MPH use the Hurricane Nailing Instructions!**



## Flush 90 Corners



## Add-On 90 Corners



## Nail Lines for Evenbutt Panels (Figure 1)

New upper line for nail placement

Original scribe line for panel alignment

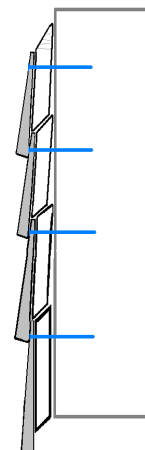
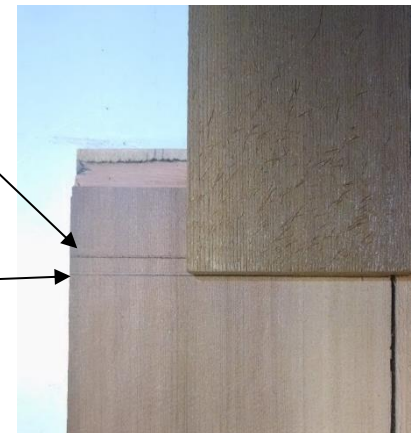

Figure 2

# 1 Course Blind Nail

Standard Nailing Instructions  
For 7-1/8", 6.0" & 5.3" *Bevel top* panels

## FLUSH CORNERS:

Flush-mounting Corner units are manufactured and supplied in four different alternating widths (marked A,B,C,D) so that the vertical corner line is eliminated. Start each course with any letter and continue in order up the corner with each row. **DO NOT** set all corners first but instead set each row as you go. This allows for adjustment if needed. You can reverse the order or even omit one of the letters if you do not repeat the same letter. Hint: save the wide pieces (B's & D's) for areas near windows or doors that might otherwise need a small section of panel. Caulk these butt joints liberally!

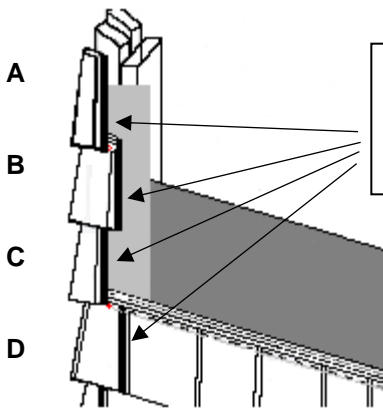

Caulk all butt joints along the cut edge of the panel's backer. Fit snugly against corner or trim.

## ANGLE CUTS:

When panels are cut horizontally or diagonally to fit gable ends, around windows or eaves, nail or staple every cut shingle close to the edge or apply molding. *Staples must be 1/4" crown stainless steel.* (Suggestion: Nail shingles to be cut before sawing, about 1/2" from saw line.)

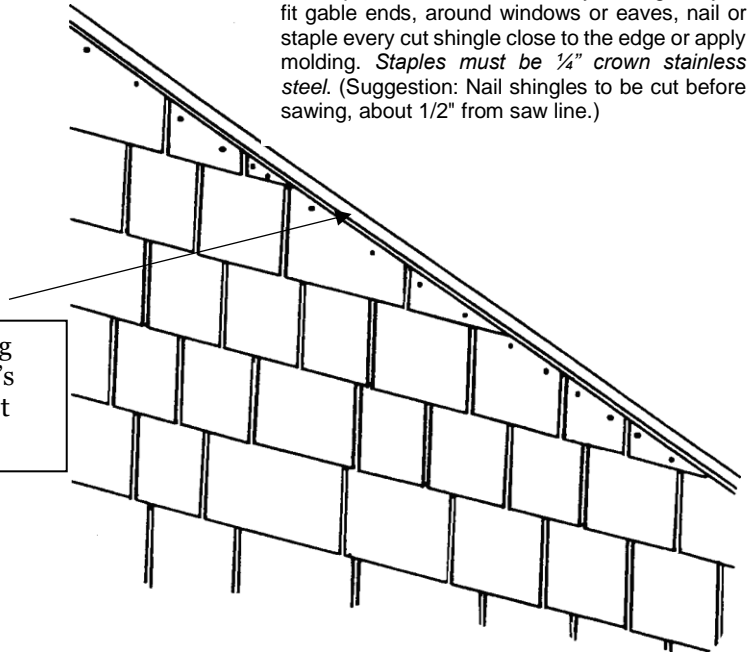

## ADD-ON CORNERS:

Add-on corners are a Boston Weave overlay shingle without a plywood backer. Install panels first running them all the way to the edge. Install the Add-On corners **OVER** the panels aligning the butt of each corner piece to the butt of the panel. **One-course starter corners must be made on site for Add-on corners. Caulk liberally while using caution that caulk does not squeeze out onto face of panel!**

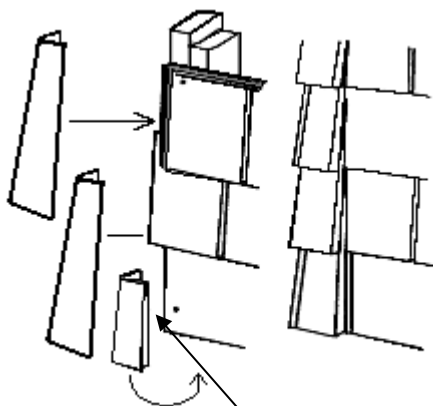

Starter piece or shims

## INSIDE CORNERS:

Nail a 1-1/2"x 1-1/2" wood strip into the inside corner and caulk sufficiently where the plywood backer will butt against it. Trim panel end square and set panel against the strip. **Use caution that caulk does not squeeze out onto face of panel!**

